

Although this document has not been updated to reflect the change to the new 6000 Series nomenclature, all dimensions and ratings are correct. In all sizes EXCEPT size 4115, the proper 6000 series can be specified by substituting a 6 for the 4. The 6000 Series equivalent to size 4115 is 6125.

Contents

SERVO 4000 SERIES

Application	128
Features & Benefits	129
Construction	130
Available Reduction Ratios	131
Type Designation	132
Selection Procedure	133
Speed Reducer Selection Sheet ..	134
Dimensions	136
Shaft Load Slow Speed Shaft	149
Recommended Load Classification	151
Mass Moment of Inertia	152
Lubrication & Installation	153

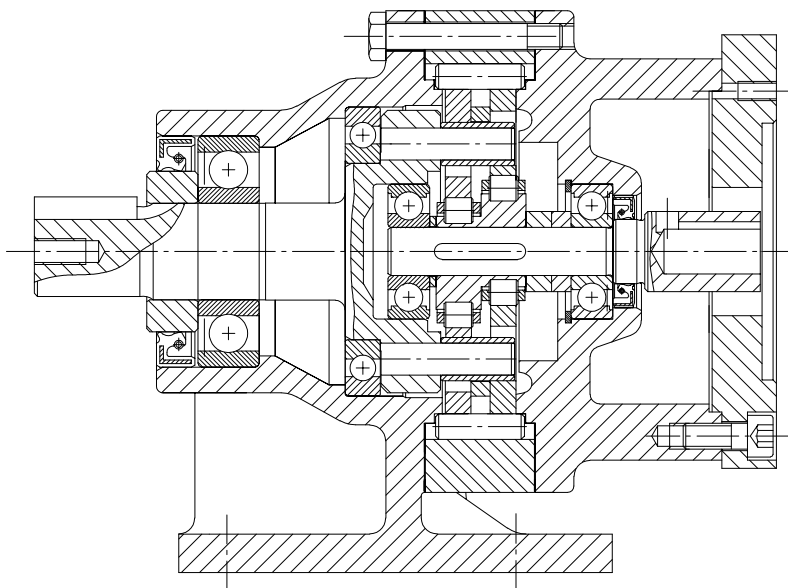

SERVO 4000

SUMITOMO CYCLO EUROPE

Precision Series

Suitable Applications for SERVO 4000-Series

Control Method	Examples of Application	Suitable Series
Positioning control	Conveyors (tact feed, sorter, palletizer) / Materials handling systems (Automatic Guideway Vehicles, Automated storage systems) / Printing machines / Machine tools (Automatic Tool Changing, Indexing tables) / Robotic systems (Positioner, Slider) / Packaging machines / Textiles machines	SERVO 4000 Low Backlash Series
Speed control	Materials handling systems / Printing machines / Machines for food industry / Conveyors / Water treatment plants / Textile industry / Paper industry	DRIVE 6000 Standard Backlash Series

Servo 4000

Compact Low Backlash Gearboxes for Positioning Control

(nominal 3 arcmin at slow speed shaft)

The SERVO 4000 series have the following features and benefits similar to the standard CYCLO DRIVE 6000 series one.

- High shock load capacity
- Compact size
- High efficiency
- Low noise
- Maintenance free
- Long life
- Unlimited mounting flexibility.

In addition the backlash has been reduced.

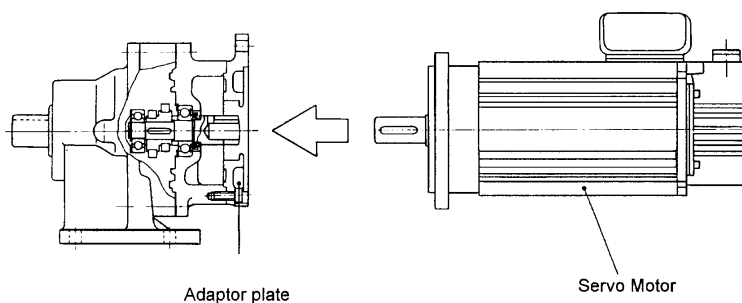

High Shock Overload Capacity

Two cycloid discs share the load equally. Therefore no pre-load is existing and a higher shock overload capacity is achievable compared to scissors types available.

High Input Speed

Max. allowable input speed is 4000 min⁻¹ (10 min cycle, 50% ED)

Easy Assembly

Quill high speed shaft and a great variety of adaptor plate designs allow easy connection with a variety of servo motor.

Low Mass Moment of Inertia

Servo control is easier, due to low inertia.

Low Noise

When compared with the sliding tooth contact of conventional gearing the rolling contact of the CYCLO system provides reduced noise level.

Due to the special tooth profile and a divided motor flange for servo motor assembly the SERVO 4000 speed reducers have low backlash without pre-load. Present drives achieve low backlash with scissors method, therefore only ½ of gears transmit power. Our products utilises all gears to transmit power, which results in "double power".

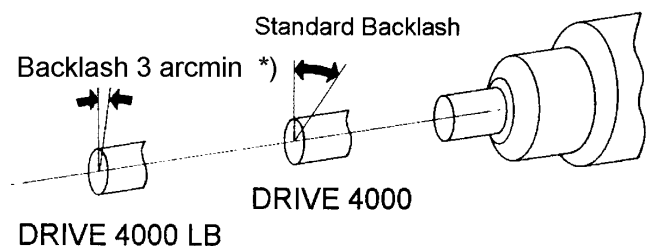

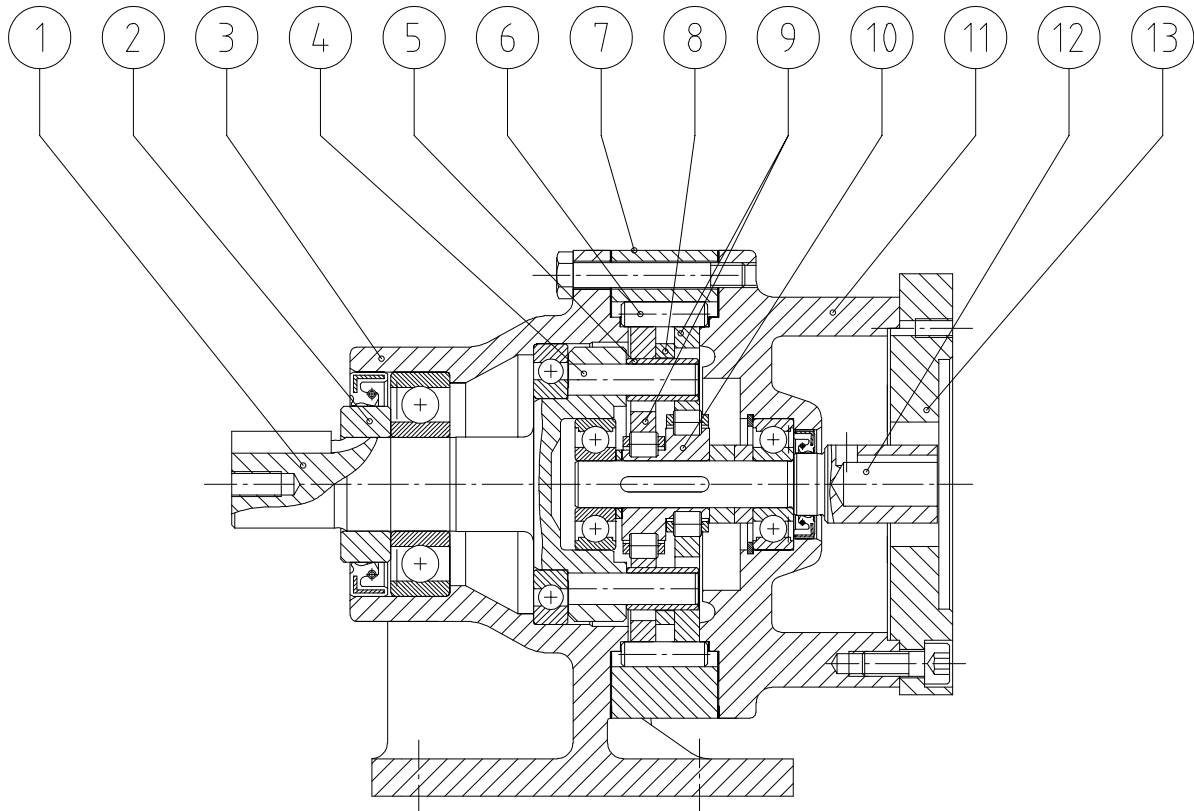

Parts No.	Parts name
1	Slow speed shaft
2	Collar
3	Casing
4	Slow speed shaft pin
5	Slow speed shaft roller
6	Ring gear housing pin
7	Ring gear housing
8	Spacer ring
9	Cycloid discs
10	Eccentric bearing
11	High speed end shield
12	High speed shaft
13	Adaptor plate

Available Reduction Ratios

Frame size	4075					4085					4095					4105					4115															
Output torque rating (Nm)	25					20	50					70	100	120					150	200	250					300	500									
Reduction ratio	11	15	21	29	43	6	11	15	21	29	43	59	6	11	15	21	29	43	59	87	6	11	15	21	29	43	59	87	6	11	15	21	29	43	59	87
Backlash	nominal 3 arcmin ^{*)}																																			
Max. allowable input speed	4000 min ⁻¹ (10 min Zyklus / cycle, 50% ED)																																			

preferred ratios on request

*) The guaranteed maximum backlash is 6 arcmin, except at ratio 6, where the max. backlash is 12 arcmin.

Notes:

- 1) The above output shaft torque rating shows the mechanical rating of CYCLO speed reducers. The acceleration and deceleration peak torque has to be less than the output shaft torque rating given in the table.
- 2) Backlash is measured by the difference in movement of output shaft at ±3% of rated output torque.
- 3) FINE CYCLO series is also available when zero backlash is necessary.
- 4) Standard backlash is also possible.

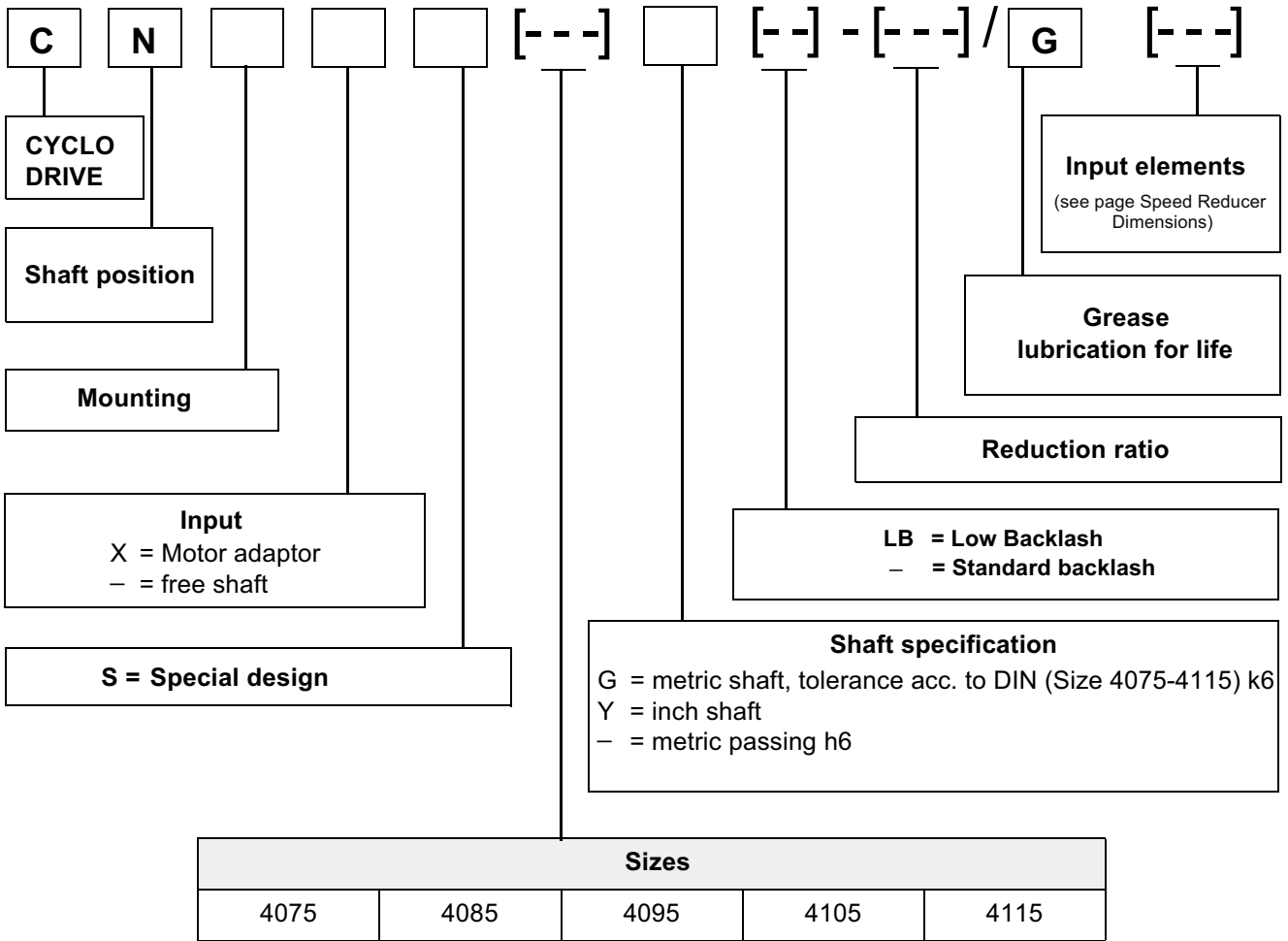

Shaft position and mounting

shaft position	mounting		
	foot mount H	F-Casing F	V-Casing V
N = universal maintenance free	CNH 	CNF 	CNV
	CNHX 	CNFX 	CNVX

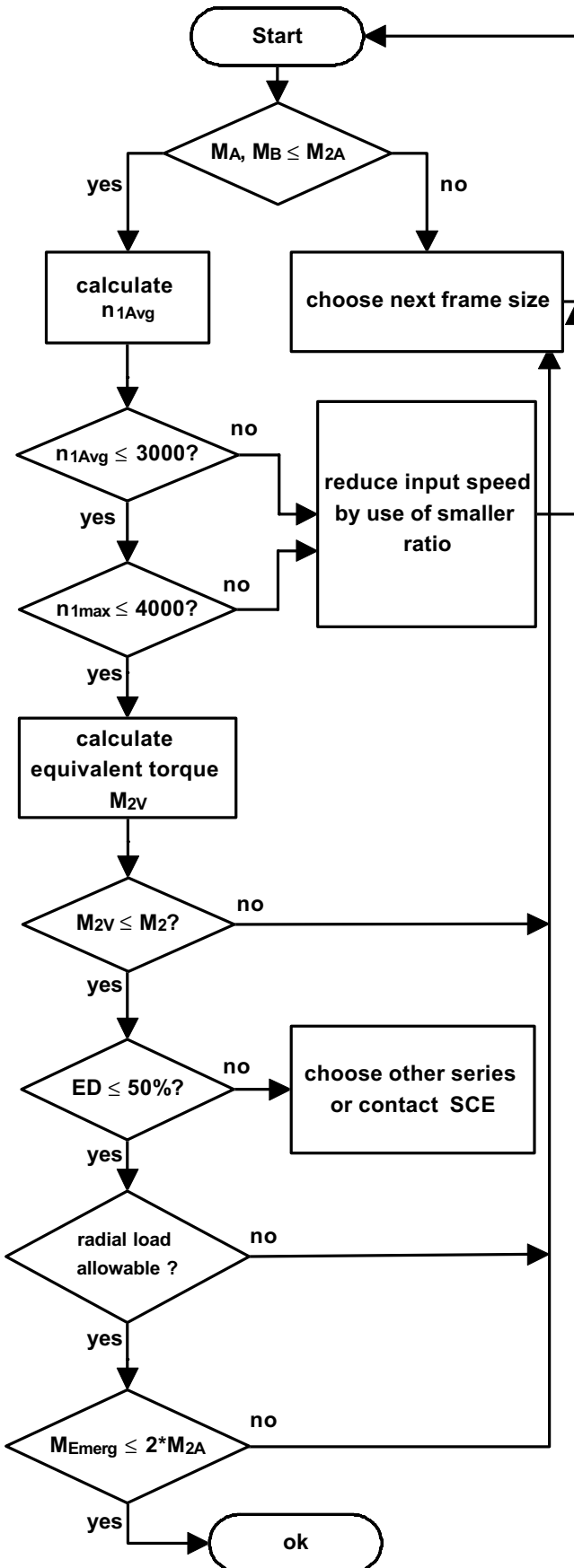

Acceleration and brake torque

Acceleration torque M_A and brake torque M_B must be smaller than allowed acceleration torque M_{2A} . The acceleration torque leads to a temporary selection of size.

Input rpm

Duration of movement

$$\Sigma t = t_A + t_B + t_R$$

average input rpm during movement

$$n_{1A} = n_{1B} = \frac{n_{1R}}{2}$$

$$n_{1m} = \frac{t_A \cdot n_{1A} + t_R \cdot n_{1R} + t_B \cdot n_{1B}}{\Sigma t} = n_{1Max} \cdot \frac{\frac{t_A + t_B}{2} + t_R}{\Sigma t}$$

Maximum input rpm must be smaller than 4000 min^{-1} , mean input rpm must be smaller than 3000 min^{-1}

Equivalent torque

$$M_{2v} = 3 \sqrt{|M_{2A}|^3 \cdot \frac{n_{1Max}}{2n_{1m}} \cdot \frac{t_A}{\Sigma t} + |M_{2R}|^3 \cdot \frac{n_{1Max}}{n_{1m}} \cdot \frac{t_R}{\Sigma t} + |M_{2B}|^3 \cdot \frac{n_{1max}}{2n_{1m}} \cdot \frac{t_B}{\Sigma t}}$$

Equivalent torque must be smaller than the allowed output torque M_2 for the chosen speed reducer at mean rpm n_{1m}

Intermediate values are calculated as follows

$$M_2 = \min\left(M_{2, 1500} \cdot \left(\frac{n_{1m}}{1500}\right)^{-0,3}, M_{2A}\right)$$

Load time ratio ED

$$ED = \frac{\Sigma t}{\Sigma t + t_D} \cdot 100$$

Load time ratio should not exceed 50%.

Radial load output side

-according to page 16 - 17.

Calculation of average rpm on output side

$$n_{2m} = \frac{n_{1m}}{i}$$

The radial load coming from the equivalent torque M_{2v} must be smaller than the allowed value at average rpm n_{2m} on output side.

The radial load coming from the acceleration torque M_A must be smaller than the allowed value at 1 rpm (output side).

Emergency torque

Peak torque in case of emergency should not exceed 200% of the allowed acceleration torque M_{2A} .

Single reduction speed reducers $i = 6$ to 87

Max. input speed is 4000 min^{-1} at 50% ED.

- n_1 = input speed [min^{-1}]
- i = reduction ratio
- n_2 = output speed [min^{-1}]
- P_1 = allowable input power [kW]
- M_2 = allowable output torque [Nm]
- M_{2A} = max. acceleration or deceleration torque [Nm]

$n_1 = 1000 \text{ min}^{-1}$

Size	i	6	11	15	21	29	43	59	87
	n_2	167	91	67	48	34	23	17	11
4075	P_1		0.15	0.15	0.13	0.08	0.06		
	M_2		14.5	19.8	25.0	21.5	25.0		
	M_{2A}		25	25	25	25	25		
4085	P_1	0.30	0.30	0.30	0.27	0.15	0.13	0.07	
	M_2	15.9	29.1	39.6	50.0	38.3	50.0	39.0	
	M_{2A}	20	50	50	50	50	50	50	
4095	P_1	0.76	0.74	0.66	0.56	0.41	0.30	0.19	0.15
	M_2	40.4	71.7	87.9	104.0	104.0	114.0	102.0	115.0
	M_{2A}	70	100	120	120	120	120	120	120
4105	P_1	1.66	1.66	1.66	1.13	0.75	0.56	0.36	0.30
	M_2	87.2	160.0	218.0	208.0	192.0	213.0	191.0	230.0
	M_{2A}	150	200	250	250	250	250	250	250
4115	P_1	3.06	3.06	2.99	2.71	1.75	1.16	0.84	0.56
	M_2	161.0	295.0	394.0	500.0	444.0	438.0	437.0	431.0
	M_{2A}	300	500	500	500	500	500	500	500

$n_1 = 1500 \text{ min}^{-1}$

Size	i	6	11	15	21	29	43	59	87
	n_2	250	136	100	71	52	35	25	17
4075	P_1		0.20	0.20	0.20	0.11	0.10		
	M_2		12.9	17.6	24.6	19.0	29.0		
	M_{2A}		25	25	25	25	25		
4085	P_1	0.40	0.40	0.40	0.40	0.20	0.20	0.10	
	M_2	14.0	25.7	35.1	49.1	33.9	50.0	34.5	
	M_{2A}	20	50	50	50	50	50	50	
4095	P_1	1.02	0.98	0.88	0.75	0.54	0.40	0.26	0.20
	M_2	35.8	63.4	77.8	92.1	92.3	101.0	90.4	102.0
	M_{2A}	70	100	120	120	120	120	120	120
4105	P_1	2.20	2.20	2.20	1.50	1.00	0.75	0.49	0.40
	M_2	77.2	142.0	193.0	184.0	170.0	189.0	169.0	204.0
	M_{2A}	150	200	250	250	250	250	250	250
4115	P_1	4.06	4.06	3.97	3.70	2.32	1.54	1.12	0.75
	M_2	143.0	261.0	349.0	455.0	393.0	388.0	387.0	382.0
	M_{2A}	300	500	500	500	500	500	500	500

Single reduction speed reducers $i = 6$ to 87

Max. input speed is 4000 min^{-1} at 50% ED.

n_1	=	input speed [min^{-1}]
i	=	reduction ratio
n_2	=	output speed [min^{-1}]
P_1	=	allowable input power [kW]
M_2	=	allowable output torque [Nm]
M_{2A}	=	max. acceleration or deceleration torque [Nm]

$n_1 = 2000 \text{ min}^{-1}$

Size	i	6	11	15	21	29	43	59	87
	n_2	333	182	133	95	69	47	34	23
4075	P_1		0.24	0.24	0.24	0.13	0.11		
	M_2		11.8	16.1	22.5	17.4	23.1		
	M_{2A}		25	25	25	25	25		
4085	P_1	0.48	0.48	0.48	0.48	0.24	0.24	0.11	
	M_2	12.9	23.6	32.2	45.1	31.1	46.2	31.7	
	M_{2A}	20	50	50	50	50	50	50	
4095	P_1	1.25	1.21	1.09	0.91	0.66	0.48	0.32	0.24
	M_2	32.8	58.2	71.4	84.5	84.7	92.3	83.0	93.4
	M_{2A}	70	100	120	120	120	120	120	120
4105	P_1	2.69	2.69	2.69	1.83	1.22	0.91	0.59	0.48
	M_2	70.8	130.0	177.0	169.0	156.0	173.0	155.0	187
	M_{2A}	150	200	250	250	250	250	250	250
4115	P_1	4.97	5.00	4.86	4.53	2.84	1.88	1.37	0.91
	M_2	131.0	240.0	320.0	417.0	361.0	355.0	355.0	350.0
	M_{2A}	300	500	500	500	500	500	500	500

$n_1 = 3000 \text{ min}^{-1}$

Size	i	6	11	15	21	29	43	59	87
	n_2	500	273	200	143	103	70	51	34
4075	P_1		0.32	0.32	0.32	0.18	0.16		
	M_2		10.5	14.3	20.0	15.4	20.4		
	M_{2A}		25	25	25	25	25		
4085	P_1	0.65	0.65	0.65	0.65	0.32	0.32	0.16	
	M_2	11.4	20.9	28.5	39.9	27.6	40.9	28.0	
	M_{2A}	20	50	50	50	50	50	50	
4095	P_1	1.66	1.60	1.44	1.22	0.88	0.65	0.42	0.32
	M_2	29.1	51.5	63.2	74.8	75.0	81.7	73.5	82.7
	M_{2A}	70	100	120	120	120	120	120	120
4105	P_1	3.57	3.57	3.57	2.44	1.62	1.22	0.79	0.65
	M_2	62.7	115.0	157.0	150.0	138.0	153.0	137.0	165.0
	M_{2A}	150	200	250	250	250	250	250	250
4115	P_1	6.60	6.60	6.45	6.01	3.77	2.50	1.82	1.22
	M_2	116.0	212.0	283.0	369.0	320.0	315.0	314.0	310.0
	M_{2A}	300	500	500	500	500	500	500	500

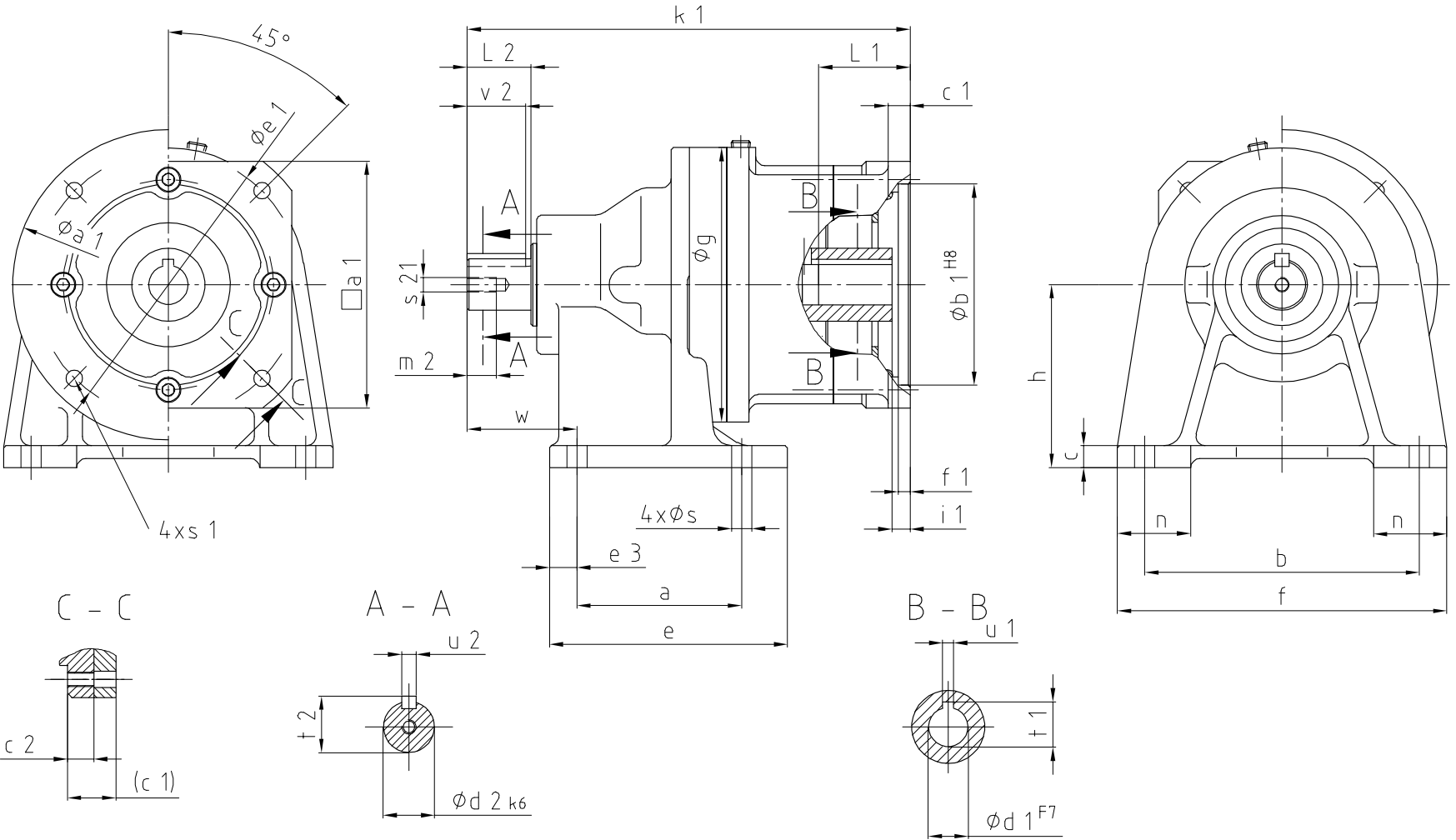

Dimensions of high speed shaft portion CNHX and dimension k1 (see Dimension Sheet Speed Reducer)

Frame size	Dimensions of Slow Speed Portion CNHX																		
												Slow Speed Shaft							kg
	a	b	c	e	e ₃	f	g ∅	h	n	s ∅	w	d ₂ ∅ k6	L ₂	u ₂	t ₂	v ₂	s ₂₁	m ₂	
4075	60	120	10	84	12	144	110	80	35	9	41	14	25	5	16.0	20	M5	10	2.5
4085	60	120	10	84	12	144	110	80	35	9	47	19	30	6	21.5	25	M6	12	2.5
4095	90	150	12	130	15	180	150	100	40	11	60	28	35	8	31.0	32	M8	16	11.0
4105	90	150	12	135	15	180	150	100	40	11	60	28	35	8	31.0	32	M8	16	13.0
4115	115	190	15	155	20	230	204	120	55	14	82	38	55	10	41.0	50	M8	16	24.0

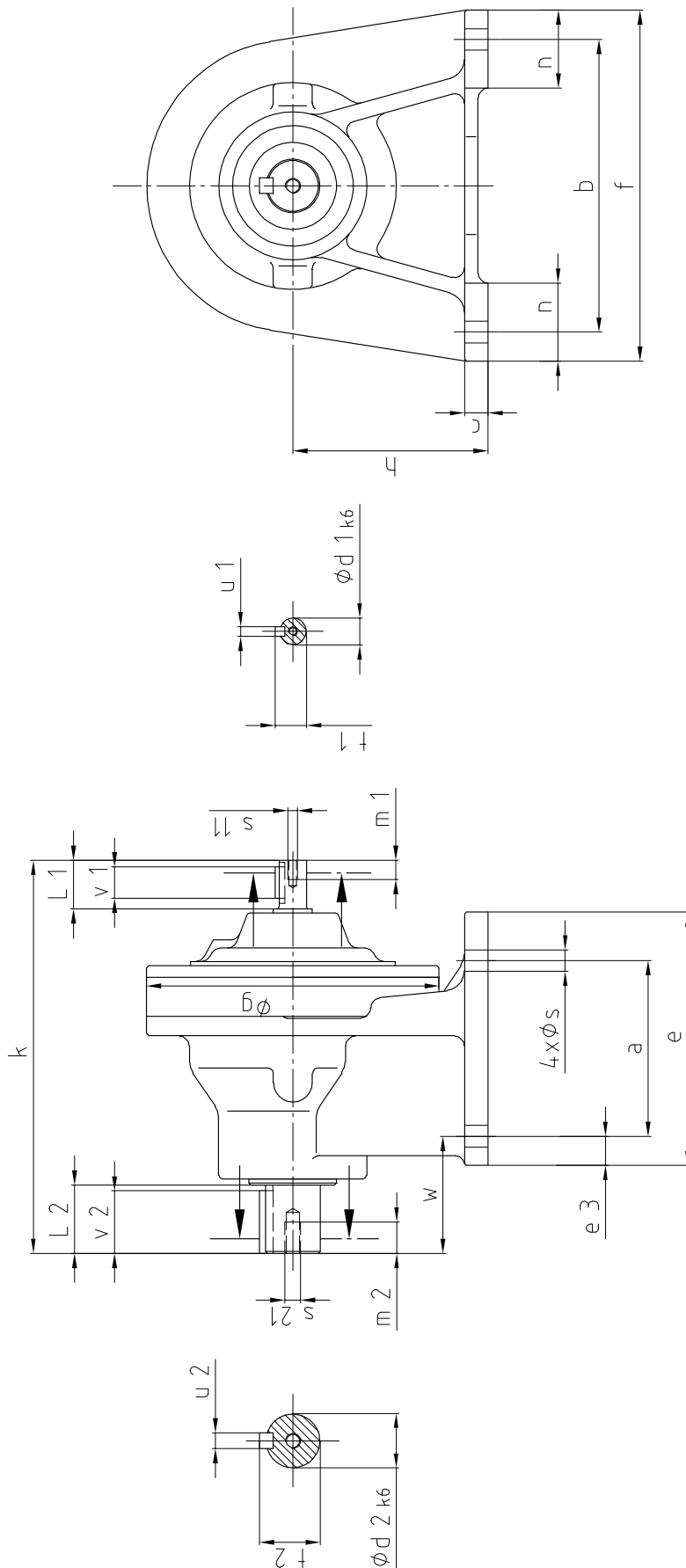

Frame size	Dimensions of slow speed portion CNH																			High speed shaft						kg	
														Slow speed shaft													
	a	b	c	e	e ₃	f	g ∅	h	k	n	s ∅	w	d ₂ ∅ k6	L ₂	u ₂	t ₂	v ₂	s ₂₁	m ₂	d ₁ ∅ k6	L ₁	u ₁	t ₁	v ₁	s ₁₁		m ₁
4075	60	120	10	84	12	144	110	80	145	35	9	41	14	25	5	16.0	20	M5	10	12	25	4	13.5	18	M4	8	2.5
4085	60	120	10	84	12	144	110	80	151	35	9	47	19	30	6	21.5	25	M6	12	12	25	4	13.5	18	M4	8	2.5
4095	90	150	12	130	15	180	150	100	202	40	11	60	28	35	8	31.0	32	M8	16	14	25	5	16.0	16	M5	10	11.0
4105	90	150	12	135	15	180	150	100	208	40	11	60	28	35	8	31.0	32	M8	16	14	25	5	16.0	16	M5	10	13.0
4115	115	190	15	155	20	230	204	120	259	55	14	82	38	55	10	41.0	50	M8	16	19	35	6	21.5	25	M6	12	24.0

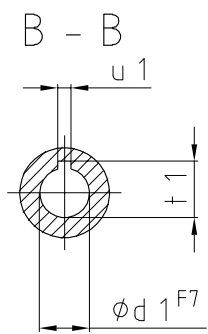
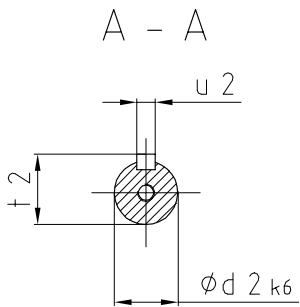
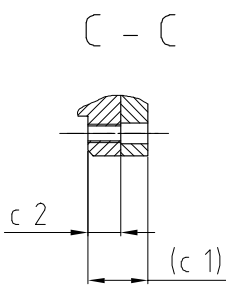
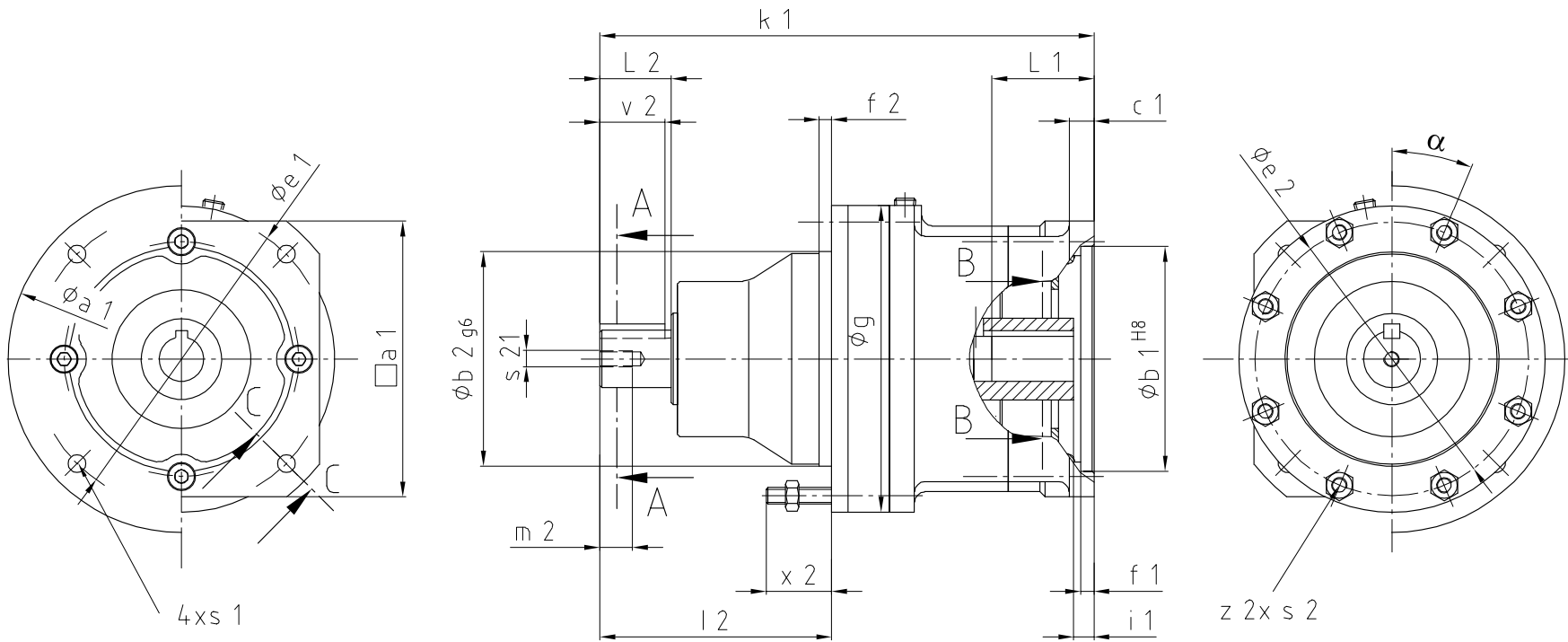

Dimensions of high speed shaft portion CNFX and dimension k1 (see Dimension Sheet Speed Reducer)

Frame size	Dimensions of Slow Speed Portion CNFX																
										Slow Speed Shaft							kg
	b_2 \emptyset g 6	e_2 \emptyset	f_2	g \emptyset	l_2	s_2	x_2	z_2	α_2	d_2 \emptyset k 6	L_2	u_2	t_2	v_2	s_{21}	m_2	
4075	75	98	4	110	69	M6	32	6	0°	14	25	5	16.0	20	M5	10	2.7
4085	80	98	4	110	74	M6	31	6	0°	19	30	6	21.5	25	M6	12	2.9
4095	105	134	6	150	114	M8	32	8	22.5°	28	35	8	31.0	32	M8	16	8.0
4105	105	134	6	150	114	M8	28	8	22.5°	28	35	8	31.0	32	M8	16	10.0
4115	140	180	14	204	139	M10	32	6	0°	38	55	10	41.0	50	M8	16	20.0

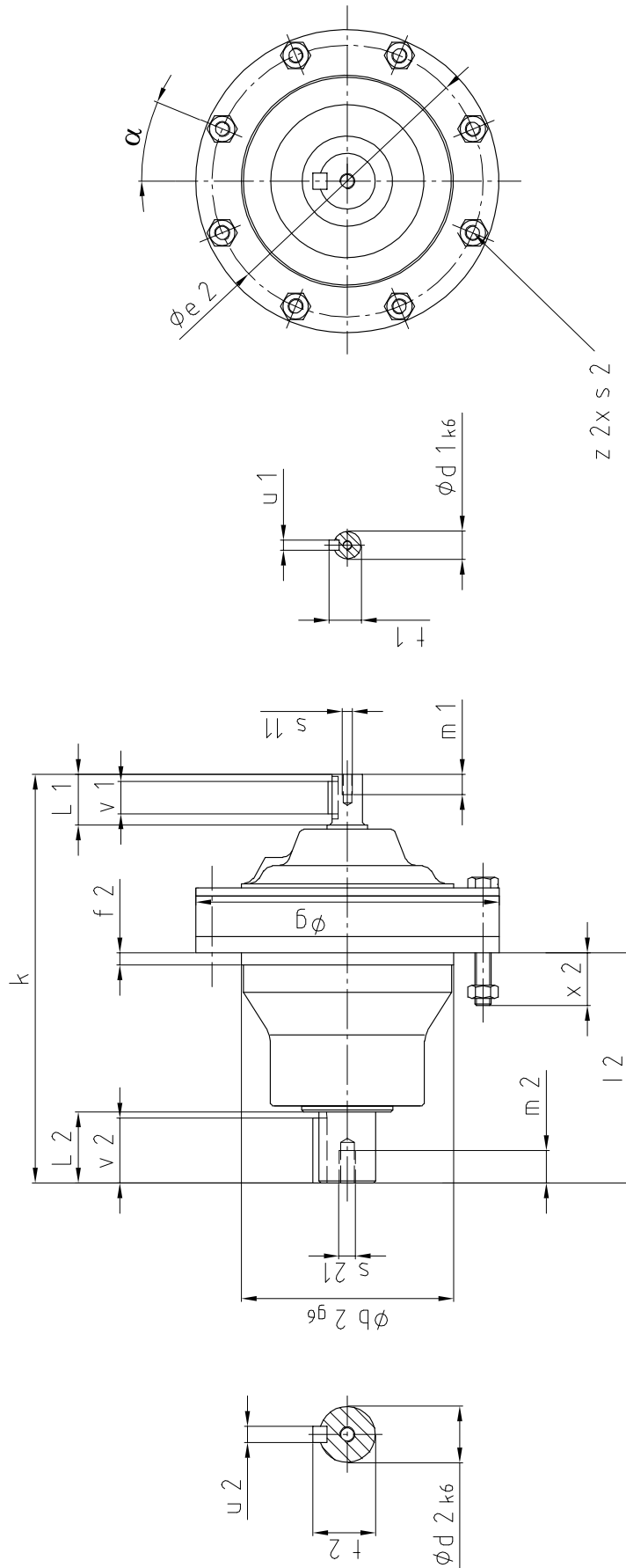

Frame size	Dimensions of slow speed portion CNF																	High speed shaft							kg
											Slow speed shaft														
	b ₂ ∅ g6	e ₂ ∅	f ₂	g ∅	l ₂	k	s ₂	x ₂	z ₂	α ₂	d ₂ ∅ k6	L ₂	u ₂	t ₂	v ₂	s ₂₁	m ₂	d ₁ ∅ k6	L ₁	u ₁	t ₁	v ₁	s ₁₁	m ₁	
4075	75	98	4	110	69	145	M6	32	6	0°	14	25	5	16.0	20	M5	10	12	25	4	13.5	18	M4	8	2.7
4085	80	98	4	110	74	151	M6	31	6	0°	19	30	6	21.5	25	M6	12	12	25	4	13.5	18	M4	8	2.9
4095	105	134	6	150	114	202	M8	32	8	22.5°	28	35	8	31.0	32	M8	16	14	25	5	16.0	16	M5	10	8.0
4105	105	134	6	150	114	208	M8	28	8	22.5°	28	35	8	31.0	32	M8	16	14	25	5	16.0	16	M5	10	10.0
4115	140	180	14	204	139	259	M10	32	6	0°	38	55	10	41.0	50	M8	16	19	35	6	21.5	25	M6	12	20.0

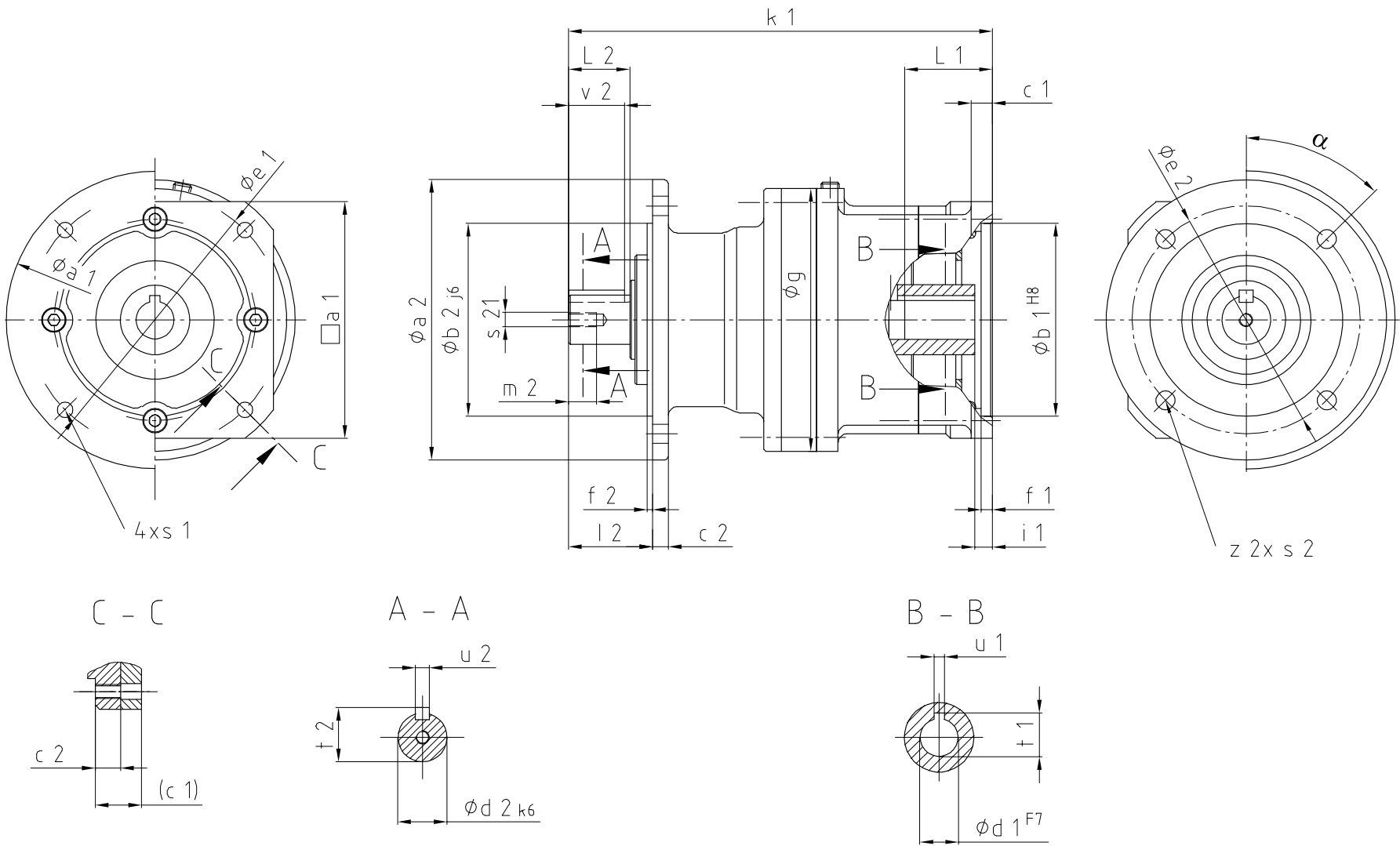

Dimensions of high speed shaft portion CNVX and dimension k1 (see Dimension Sheet Speed Reducer)

Frame size	Dimensions of Slow Speed Portion CNVX																	kg
											Slow Speed Shaft							
	a ₂ ∅	b ₂ ∅ j6	c ₂	e ₂ ∅	f ₂	g ∅	l ₂	s ₂ ∅	z ₂	α ₂	d ₂ ∅ k6	L ₂	u ₂	t ₂	v ₂	s ₂₁	m ₂	
4075	120	80	8	100	3	110	34	9	6	30°	14	25	5	16.0	20	M5	10	3.5
4085	160	110	9	130	3	110	42	11	4	45°	19	30	6	21.5	25	M6	12	4.5
4095	160	110	9	130	3	150	48	11	4	45°	28	35	8	31.0	32	M8	16	9
4105	160	110	9	130	3	150	48	11	4	45°	28	35	8	31.0	32	M8	16	11
4115	200	130	13	165	4	204	69	11	6	30°	38	55	10	41.0	50	M8	16	23

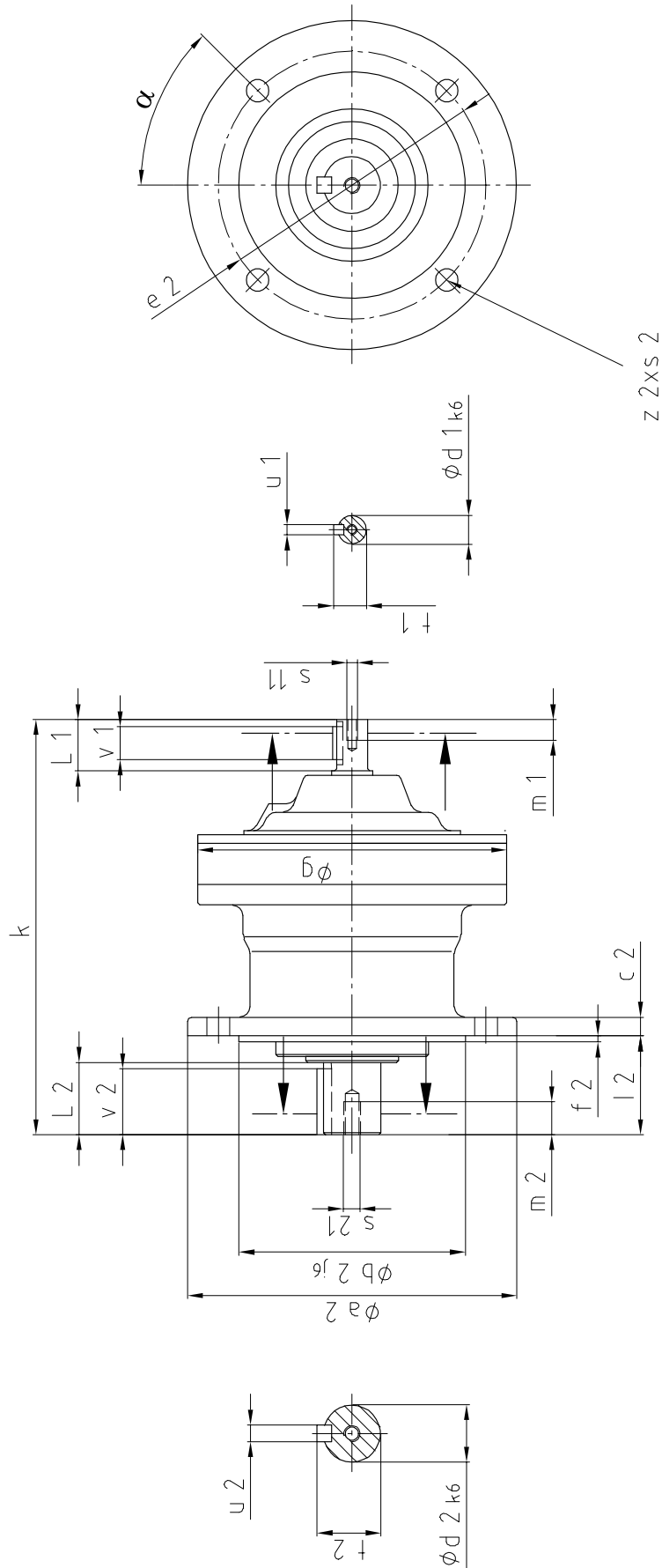

Frame size	Dimensions of slow speed portion CNV																			High speed shaft						kg
													Slow speed shaft													
	a ₂ ∅	b ₂ ∅ j6	c ₂	e ₂ ∅	f ₂	g ∅	k	l ₂	s ₂ ∅	z ₂	α ₂	d ₂ ∅ k6	L ₂	u ₂	t ₂	v ₂	s ₂₁	m ₂	d ₁ ∅ k6	L ₁	u ₁	t ₁	v ₁	s ₁₁	m ₁	
4075	120	80	8	100	3	110	145	34	9	6	30°	14	25	5	16.0	20	M5	10	12	25	4	13.5	18	M4	8	3.5
4085	160	110	9	130	3	110	151	42	11	4	45°	19	30	6	21.5	25	M6	12	12	25	4	13.5	18	M4	8	4.5
4095	160	110	9	130	3	150	202	48	11	4	45°	28	35	8	31.0	32	M8	16	14	25	5	16.0	16	M5	10	9
4105	160	110	9	130	3	150	208	48	11	4	45°	28	35	8	31.0	32	M8	16	14	25	5	16.0	16	M5	10	11
4115	200	130	13	165	4	204	259	69	11	6	30°	38	55	10	41.0	50	M8	16	19	35	6	21.5	25	M6	12	23

Dimensions of high speed shaft portion
CNHX, CNFX, CNVX

Frame size	High speed shaft portion																	
	Input element	a ₁ □	a ₁ ∅	b ₁ ∅ H8	c ₁	c ₂	e ₁ ∅	f ₁	k ₁	s ₁ ∅	d ₁ ∅ F7	l ₁	L ₁	u ₁	t ₁	kg CNHX	kg CNFX	kg CNVX
4075	12/65		99	50	10		65	4	159	M5	12	5	30	4	13.8	4	4	4.5
	11/75		99	60	10		75	4	159	M5	11	5	23	4	12.8	4	4	4.5
	14/85		99	70	12		85	4	159	M6	14	5	30	5	16.3	4	4	4.5
	14/100		135	80	12		100	4	159	M6	14	5	30	5	16.3	4.5	4.5	5
	11/115		135	95	16		115	4	159	M8	11	5	23	4	12.8	4.5	4.5	5
	12/115		135	95	16		115	4	159	M8	12	5	30	4	13.8	4.5	4.5	5
	14/115		135	95	16		115	4	159	M8	14	5	30	5	16.3	4.5	4.5	5
4085	14/85		99	70	12		85	4	165	M6	14	5	30	5	16.3	4	4	4.5
	14/100		135	80	12		100	4	165	M6	14	5	30	5	16.3	4.5	4.5	6
	19/100	90		80	12		100	4	176	M6	19	10	40	6	21.8	4.5	4.5	6
	11/115		135	95	16		115	4	165	M8	11	5	23	4	12.8	4.5	4.5	6
	14/115		135	95	16		115	4	165	M8	14	5	30	5	16.3	4.5	4.5	6
	19/115		135	95	16		115	4	173	M8	19	7	40	6	21.8	4.5	4.5	6
	14/130		155	110	16		130	4	165	M8	14	5	30	5	16.3	4.5	4.5	6
19/130	120		110	23	12	130	4	173	M8	19	7	40	6	21.8	4.5	4.5	6	
4095	11/100		135	80	12		100	4	217	M6	11	5	23	4	12.8	12.5	10.5	11.5
	14/100		135	80	12		100	4	217	M6	14	5	30	5	16.3	12.5	10.5	11.5
	16/100	90		80	12		100	4	228	M6	16	9	40	5	18.3	12	10	11
	19/100	90		80	12		100	4	228	M6	19	10	40	6	21.8	12	10	11
	14/115		135	95	16		115	4	217	M8	14	5	30	5	16.3	12.5	10.5	11.5
	19/115		135	95	16		115	4	225	M8	19	7	40	6	21.8	13	11	12
	24/115		135	95	16		115	4	243	M8	24	9	50	8	27.3	13.5	11.5	12.5
	14/130		155	110	16		130	4	217	M8	14	5	30	5	16.3	13	11	12
	16/130	120		110	23	12	130	4	225	M8	16	6	40	5	18.3	13	11	12
	19/130	120		110	23	12	130	4	225	M8	19	7	40	6	21.8	13	11	12
	19/145		170	110	12		145	6	223	M8	19	8	40	6	21.8	13.5	11.5	12.5
	22/145	135		110	12		145	6	242	∅9	22	10	50	6	24.8	13.5	11.5	12.5
	24/145	135		110	12		145	6	242	∅9	24	8	50	8	27.3	13.5	11.5	12.5
19/200		230	114.3	12		200	6	233	∅14	19	8	40	6	21.8	14	12	13	
22/200	180		114.3	12		200	6	247	∅14	22	15	50	6	24.8	14	12	13	
4105	14/100		135	80	12		100	4	231	M6	14	5	30	5	16.3	12.5	9.5	10.5
	16/100	90		80	12		100	4	242	M6	16	9	40	5	18.3	12.5	9.5	10.5
	19/100	90		80	12		100	4	242	M6	19	9	40	6	21.8	12.5	9.5	10.5
	19/115		135	95	16		115	4	239	M8	19	6	40	6	21.8	12.5	9.5	10.5
	24/115		135	95	16		115	4	257	M8	24	9	50	8	27.3	12.5	9.5	10.5
	24/130	120		110	23	12	130	4	254	M8	24	6	50	8	27.3	13	10	11
	28/130		155	110	16		130	4	266	M8	28	8	60	8	31.3	13	10	11
	19/145		170	110	12		145	6	247	M8	19	6	40	6	21.8	13	10	11
	19/165		190	110	15		165	6	254	∅11	19	13	40	6	21.8	13	10	11
	24/165		190	110	15		165	6	254	∅11	24	6	50	8	27.3	13	10	11
	19/200		230	114.3	15		200	6	247	∅14	19	6	40	6	21.8	14	11	12
	28/235	220		200	15		235	4	272	∅14	28	14	60	8	31.3	14.5	11.5	12.5
4115	19/115		135	95	16		115	4	271	M8	19	8	40	6	21.8	27.5	27.5	30.5
	19/130	120		110	23	12	130	4	271	M8	19	8	40	6	21.8	27.5	27.5	30.5
	28/130		155	110	16		130	4	298	M8	28	8	60	8	31.3	27.5	27.5	30.5
	19/165		190	110	15		165	6	286	∅11	19	13	40	6	21.8	28	28	31
	24/165		190	110	15		165	6	286	∅11	24	7	50	8	27.3	28	28	31
	32/165		190	110	15		165	6	308	∅11	32	10	60	10	35.3	28	28	31
	19/200		230	114.3	15		200	6	279	∅14	19	6	40	6	21.8	28	28	31
	22/200	180		114.3	15		200	6	293	∅14	22	15	50	6	24.8	28	28	31
	35/200	180		114.3	15		200	6	311	∅14	35	13	80	10	38.3	28	28	31
	28/215		250	180	15		215	6	306	∅14	28	16	60	8	31.3	28	28	31
	32/215		250	180	15		215	6	306	∅14	32	8	60	10	35.3	28	28	31
24/235		270	200	15		235	6	289	∅14	24	10	50	8	27.3	29	28	31	

Radial load

The applied radial load is calculated as below:

$$F_{Rq} = \frac{2 \cdot 10^3 \cdot M_{ef} \cdot f_{B1} \cdot L_f \cdot C_f}{d_o} = [N]$$

$$F_{R2} \geq F_{Rq}$$

- F_{Rq} = Equivalent radial load [N] for the selection of a SERVO 4000 speed reducer
- F_{R2} = Allowable radial load [N] at mid slow speed shaft
- M_{ef} = Effectively required output torque [Nm]
- f_{B1} = Service factor
- L_f = Correction factor for load position on slow speeds.
- d_o = Pitch circle diameter of the drive element [mm]
- C_f = Correction factor for type of drive connection

Tab. 6
Load correction factor C_f

	C_f
Chain	1.00
Pinion	1.25
V-Belt	1.25

Service factor f_{B1}

input	daily duty	nature of load of the driven machine (also see page Recommended Load Classification)		
		U uniform load	M moderate shocks	H heavy shocks
		f_{B1}		
electric motor	occasional, 30 min per day	0.50	0.80	1.20
	intermittent, 3 hours per day	0.80	1.00	1.35
	8 hours per day	1.00	1.20	1.50
	16 hours per day	1.10	1.28	1.55
	24 hours per day	1.20	1.35	1.60

Correction factor L_f for load position

Size	l [mm]											
	5	10	15	20	25	30	35	40	45	50	60	70
4075	0,83	0,94	1,19	1,56								
4085	0,82	0,91	1,00	1,29	1,59	1,88						
4095	0,86	0,92	0,97	1,13	1,38	1,64	1,90					
4105	0,86	0,92	0,97	1,13	1,38	1,64	1,90					
4115		0,82	0,87	0,92	0,97	1,08	1,25	1,42	1,59	1,76		

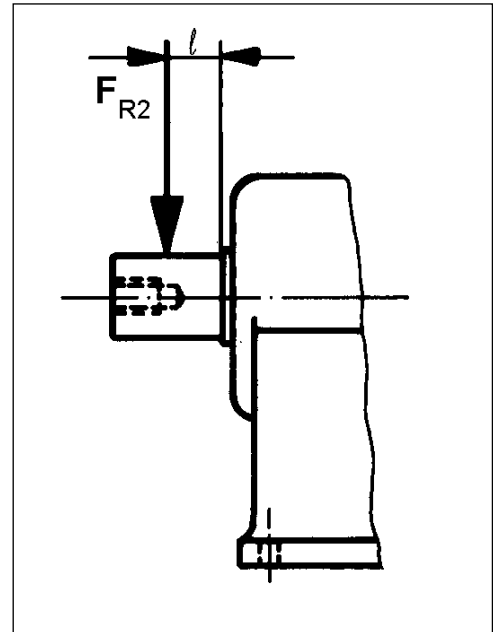

Radial load FR_{2} at mid slow speed shaft

n_2 [min ⁻¹]	Size				
	4075	4085	4095	4105	4115
1	1200	1800	3400	5500	8800
2	1200	1800	3400	5500	8800
3	1200	1800	3400	5500	8800
4	1200	1800	3400	5500	8800
5	1200	1800	3400	5500	8800
6	1200	1800	3400	5500	8800
8	1200	1800	3400	5500	8800
10	1200	1800	3400	5500	8800
15	1200	1800	3400	5500	8800
20	1200	1800	3400	5500	8800
25	1200	1800	3400	5500	8800
30	1200	1800	3400	5500	8800
35	1200	1800	3400	5500	8800
40	1200	1800	3400	5500	8800
50	1200	1800	3400	5500	8800
60	1200	1800	3400	5500	8340
80	1200	1800	3400	5500	7580
100	1100	1800	3400	5500	7040
125	1040	1760	3310	5210	6530
150	980	1660	3110	4900	6140
200	890	1510	2830	4450	5580
250	-	1400	2630	4140	5180
300	-	1310	2480	3890	4880

TYPE OF APPLICATIONTYPE OF LOAD**CONVEYORS****-UNIFORMLY LOADED**

Belt conveyors	U
Bucket conveyors	U
Assembly lines	U
Chain conveyors	U
Freight elevators	U
Apron conveyors	U
Screw conveyors	U

CONVEYORS**-HEAVY DUTY**

Belt conveyors	M
Bucket conveyors	M
Assembly lines	M
Chain conveyors	M
Freight elevators	M
Apron conveyors	M
Screw conveyors	M

METAL WORKING MACHINES

Bending or straightening machines	M
Presses	H
Plate shears	M
Machine tools	M
- main drives	U
- auxiliary drives	M

TEXTILE INDUSTRY

Dyeing machines	M
Tanning vats	M
Calenders	M
Willows	M
Looms	M

MHI INDUSTRY

Slider	M
Positioner	M

U = uniform load**M = moderate shocks****H = heavy shocks****R = consult SUMITOMO CYCLO EUROPE**

The inertia of the SERVO 4000 speed reducer depends on the frame size and the hollow input shaft diameter of the input shaft. By adding J_1 (table 1) and J_2 (table 2) you get the complete value of J_{Ges} .

$$J_{Ges} = J_1 + J_2$$

Inertia J_1 depending on frame size and reduction ratio

($\text{kgm}^2 * 10^{-4}$)

Frame size	Reduction ratio							
	6	11	15	21	29	43	59	87
4075		0.11500	0.08275	0.07675	0.09725	0.09500		
4085	0.15100	0.12025	0.08475	0.07750	0.09800	0.09525	0.09400	
4095	0.96750	0.60250	0.49750	0.29750	0.33750	0.26000	0.19475	0.19200
4105	0.78250	0.35250	0.21100	0.14825	0.17725	0.15750	0.14650	0.14200
4115	3.15000	1.61250	0.96750	0.74500	0.96000	0.87750	0.84000	0.81250

Inertia J_2 depending on the motor shaft diameter

($\text{kgm}^2 * 10^{-4}$)

Frame size	Motor shaft diameter									
	Ø 11	Ø 12	Ø 14	Ø 16	Ø 19	Ø 22	Ø 24	Ø 28	Ø 32	Ø 35
4075	0.12100	0.12525	0.10575							
4085	0.12175		0.10650							
4095	0.14850		0.13350	0.14475	0.99500	1.05000	1.05000			
4105			0.13575	0.14725	0.99750		1.05250	2.30750		
4115					1.22500	1.28000	1.26000	2.55000	3.12500	3.15000

Example: SERVO 4000 speed reducer size 4075, reduction ratio 11; motor adaptor for shaft diameter Ø 11

$$J_1 = 0.115 \text{ kgm}^2 * 10^{-4}$$

$$J_2 = 0.121 \text{ kgm}^2 * 10^{-4}$$

$$J_{Ges} = J_1 + J_2 = 0.236 \text{ kgm}^2 * 10^{-4}$$

Grease Lubrication (G)

Grease lubricated Servo 4000 units are filled with grease at our factory and are ready for use without refilling. The grease used must not be mixed with other types of grease. The standard grease type Shell Alvania RA is suitable for ambient temperatures of -10°C to +50°C. Please contact us if considering use of standard grease outside this temperature range as well as the use of any other lubricants.

All Servo 4000 units can be mounted in any position required. The service life can be increased if the grease is replaced after 20,000 hours or every 4 to 5 years.

The grease may no longer be in perfect condition if the unit has not been used for longer than 1 year. In this case, the DRIVE unit should be disassembled and the grease replaced.

Size	4075	4085	4095	4105	4115
Grease quantity [g]	30	45	125	210	380

Installation and Operation

When mounting the servo motor, grease should be applied on the motor shaft.

When mounting the servo motor, the shaft centre of SERVO 4000 speed reducer and servo motor is to be aligned carefully.

When tightening bolts to mount the servo motor, tightening has to be done only after matching of the pilot of servo motor and adaptor plate. Mismatching of the pilot may cause the failure of input shaft bearing.